

## PlayPanel Cantilever Legs - Set of 2

Lightweight plastic support legs for PlayPanels®

MODEL #: CF900-903



### OVERVIEW:

Ensure stability by connecting these weighted plastic Cantilever legs to PlayPanels®. We recommend one set of Cantilever Legs for every 3-4 panels.

### MATERIALS:

Cantilever legs are constructed of molded plastic.

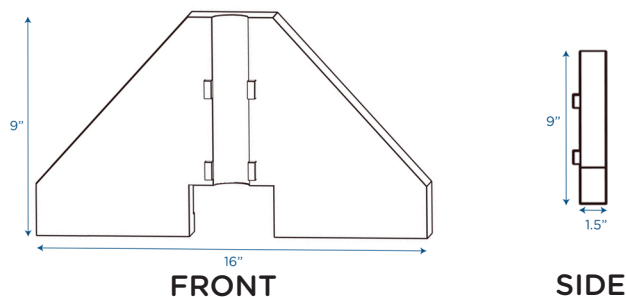
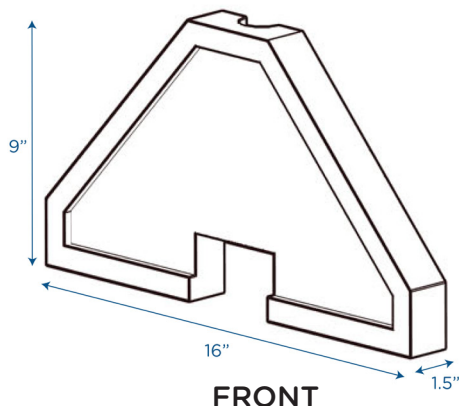

Digital Switches:



Model #	Description	L"	W"	H"	WT lbs.	Cube	FC	Truck Only
CF900-903	PlayPanel Cantilever Legs - Set of 2	16	1.5	9	5			N
	Shipping Dimensions	13.125	13.625	4.5	5.6	0.47	92.5	

### ADDITIONAL INFORMATION:

**AGE RATING:** General Use

**STANDARDS AND TEST COMPLIANCE:** USAAH000784  
PASS Mar 2020 ASTM, EN, SOR,

**GREENGUARD GOLD CERTIFIED:** NO

**WARRANTY:** 2 Years

**KEYWORDS:** Partition room dividers; room divider screens; Room partition; screen room divider; playroom; Privacy screen room divider; panel room divider; Classroom dividers; daycare furniture; homeschool; Montessori; playroom; room partition; 2 panel room divider; 4 panel room divider; 6 panel room divider; 3 panel room divider