

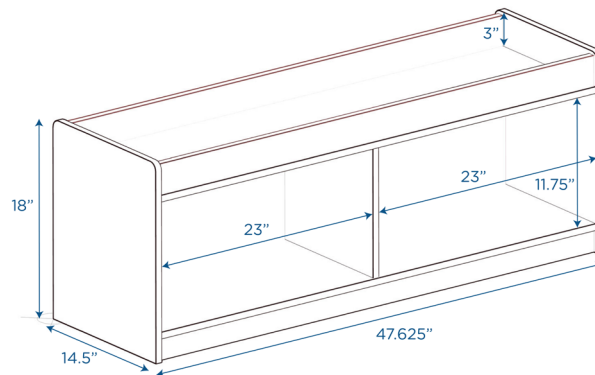

Value Line™ Birch Toddler Storage with Mirror Back

2-shelf storage with mirror back

MODEL #: ANG9177



FRONT

OVERVIEW:

Unit features dowel-pin/cam-lock construction and ships unassembled with clear instructions, tools and hardware for easy assembly. Storage areas measure 23"l x 11-1/2"h. Additional top storage measures 46.5"l x 3"h. Shatter resistant, acrylic mirror measures 46.5"l x 12.375"h.

MATERIALS:

This storage unit is constructed from strong, 11-ply 5/8" thick birch veneer panels and a recessed 1/4" thick woodgrain back panel with a tough water-based clear UV that is extremely scratch-, dent- and stain-resistant. Unit features kick plates and rounded corners for safety.

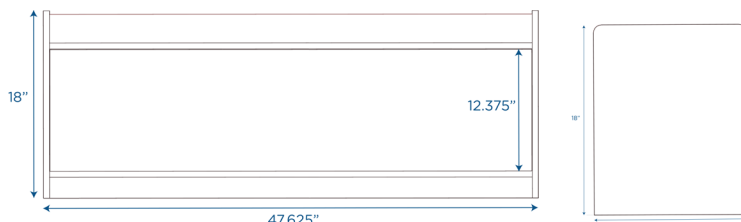

BACK

SIDE

Digital Swatches:



Model #	Description	L"	W"	H"	WT lbs.	Cube	FC	Truck Only
ANG9177	Value Line™ Birch Toddler Storage with Mirror Back	47.625	14.5	18	42			N
	Shipping Dimensions	54	17	5	46	2.66	150	

ADDITIONAL INFORMATION:

AGE RATING: General Use

STANDARDS AND TEST COMPLIANCE: N/A

GREENGUARD GOLD CERTIFIED: Yes

WARRANTY: Limited Lifetime

KEYWORDS: storage shelves; storage shelf; mirror; kids mirror; baby mirror; tummy time mirror; nursery furniture; reading nook; classroom organization; classroom; preschool; daycare furniture; homeschool; kids storage organizer; kids storage; kids toy storage organizer; kids toy storage; kids organizers and storage; classroom storage; playroom; book shelf organizer for kids; cubbies storage for kids; kids cubby; toy storage for toddlers; nursery book shelves