

Value Line™ Birch Reading Nook

Wooden seating nook with book storage and windows

MODEL #: ANG9002

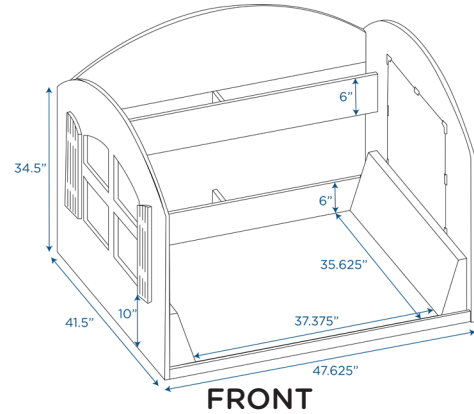

FRONT

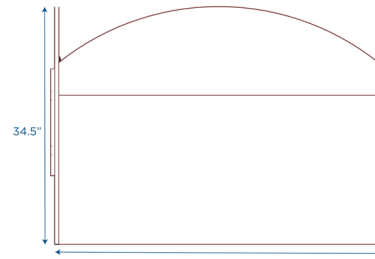

BACK

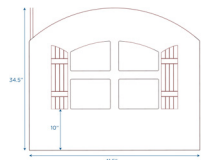

SIDE

OVERVIEW:

Unit features dowel-pin/cam-lock construction and ships unassembled with clear instructions, tools and hardware for easy assembly. Unit features acrylic windows on the side panels.

MATERIALS:

This unit is constructed from strong, 11-ply 5/8" thick birch veneer panels and a recessed 1/4" thick woodgrain back panel with a tough water-based clear UV that is extremely scratch-, dent- and stain-resistant. Unit features rounded corners for safety. Foam seat pad and back rests are covered in soft and durable vegan leather that is easy to wipe clean and bleach/water cleanable.

Digital Swatches:



| Model # | Description | L" | W" | H" | WT lbs. | Cube | FC | Truck Only |
|---------|--------------------------------|--------|------|------|---------|-------|-----|------------|
| ANG9002 | Value Line™ Birch Reading Nook | 47.625 | 41.5 | 34.5 | 85 | | | Y |
| | Shipping Dimensions | 56 | 36 | 10 | 89 | 11.67 | 150 | |

ADDITIONAL INFORMATION:

AGE RATING: General Use

STANDARDS AND TEST COMPLIANCE: N/A

GREENGUARD GOLD CERTIFIED: Yes

WARRANTY: Limited Lifetime

KEYWORDS: classroom; classroom organization; preschool; daycare furniture; nursery furniture; reading nook; reading nook for kids; kids reading nook; playroom storage; playroom; playroom organization and storage; playroom furniture; homeschool; book display; book display stand; book display kids; homeschool organizers and storage; classroom storage; book bins for classroom; flexible seating; flexible seating for classroom elementary