

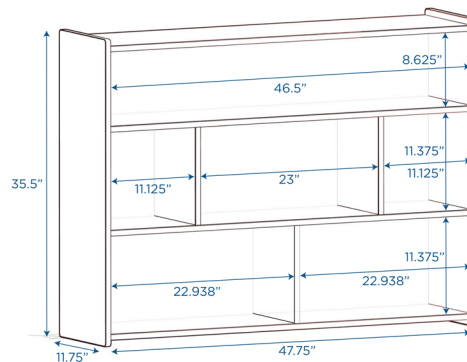

## Value Line 3-Shelf Storage

Wooden storage shelf with 6 separate compartments

MODEL #: ANG7150



FRONT

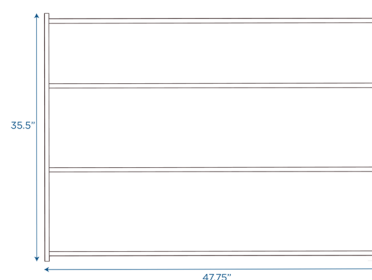

BACK



SIDE

### OVERVIEW:

Unit ships unassembled with clear instructions, tools and hardware for easy assembly. Large storage area measures 46-1/2"l x 8-5/8"h, 3 medium storage areas measure 23"l x 11-3/8"h, and 2 small storage areas measure 11-3/8"l x 11-3/8"h.

### MATERIALS:

This 3-shelf storage unit is constructed from durable, maple-faced melamine panels with a clear, water-based laminate finish that is extremely scratch-, dent- and stain-resistant. Unit features rounded corners for safety.

Digital Swatches:



Model #	Description	L"	W"	H"	WT lbs.	Cube	FC	Truck Only
ANG7150	Value Line™ 3-Shelf Storage	47.75	11.75	35.5	73			N
	Shipping Dimensions	54	15	5	72	2.34	70	

### ADDITIONAL INFORMATION:

**AGE RATING:** General Use

**STANDARDS AND TEST COMPLIANCE:** SHAH00902884  
PASS - Jan 19, 2018ASTM, CPSC Regulations

**GREENGUARD GOLD CERTIFIED:** Yes

**WARRANTY:** Limited Lifetime

**KEYWORDS:** storage shelves; storage shelf; nursery furniture; classroom organization; classroom; preschool; daycare furniture; homeschool; kids storage organizer; kids storage; kids toy storage organizer; kids toy storage; kids organizers and storage; classroom storage; daycare furniture; book shelf organizer for kids; cubbies storage for kids; kids cubby; toy storage for toddlers; nursery book shelves