

Toddler Book Center
Wooden 5-shelf book case

MODEL #: ANG1697

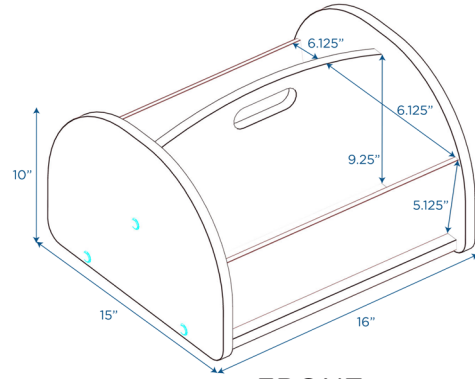

FRONT

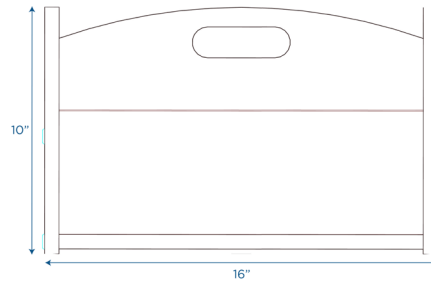

BACK

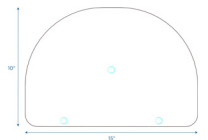

SIDE

OVERVIEW:

Unit ships fully assembled. This small book display unit features two sides to store books, each with a clear, acrylic panel. Each bookshelf measures 15"l x 5-1/8"h.

MATERIALS:

This book display is constructed from strong, 11-ply 5/8" thick birch veneer panels with a tough water-based clear UV that is extremely scratch-, dent- and stain-resistant. Unit features rounded corners for safety.

Digital Swatches:



Model #	Description	L"	W"	H"	WT lbs.	Cube	FC	Truck Only
ANG1697	Toddler Book Center	16	15	10	12			N
	Shipping Dimensions	18	17	13	13	2.30	150	

ADDITIONAL INFORMATION:

AGE RATING: General Use

STANDARDS AND TEST COMPLIANCE: SHAH00902881
PASS Jan 2018 CSPC

GREENGUARD GOLD CERTIFIED: Yes

WARRANTY: Limited Lifetime

KEYWORDS: classroom furniture; classroom organization; preschool; daycare furniture; nursery furniture; reading nook; reading nook for kids; kids reading nook; playroom storage; book shelf organizer; book shelf; book shelf organizer for kids; playroom; playroom organization and storage; playroom furniture; book display; book display stand; book display kids; homeschool organizers and storage; classroom storage; book bins for classroom; kids book display; book display shelf