

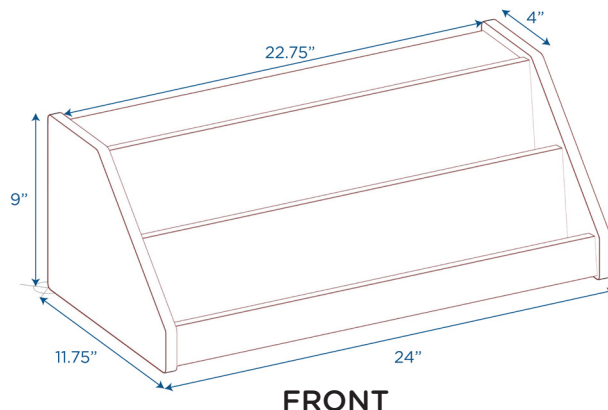

Infant/Toddler Book Display

Wooden shelf storage with horizontal, vertical and bin storage

MODEL #: ANG1601



FRONT



BACK

SIDE

OVERVIEW:

Unit ships fully assembled. Easy-reach display features 2 tiered shelves.

MATERIALS:

This storage unit is constructed from strong, 11-ply 5/8" thick birch veneer panels and a recessed 1/4" thick woodgrain back panel with a tough water-based clear UV that is extremely scratch-, dent- and stain-resistant. Unit features kick plates and rounded corners for safety.

Digital Swatches:



Model #	Description	L"	W"	H"	WT lbs.	Cube	FC	Truck Only
ANG1601	Infant/Toddler Book Display	24	11.75	9	11			N
	Shipping Dimensions	26	14	11	14	2.32	150	

ADDITIONAL INFORMATION:

AGE RATING: General Use

STANDARDS AND TEST COMPLIANCE: N/A

GREENGUARD GOLD CERTIFIED: Yes

WARRANTY: Limited Lifetime

KEYWORDS: classroom furniture; classroom organization; preschool; daycare furniture; nursery furniture; reading nook; reading nook for kids; kids reading nook; playroom storage; book shelf organizer; book shelf; book shelf organizer for kids; playroom; playroom organization and storage; playroom furniture; book display; book display stand; book display kids; homeschool organizers and storage; classroom storage; book bins for classroom; kids book display; book display shelf