

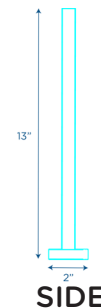

Quiet Divider® with Sound Sponge® Set of 2 Support Feet

2 plastic support feet for Quiet Divider® panels

MODEL #: AB8611

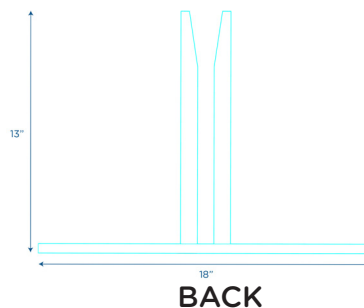
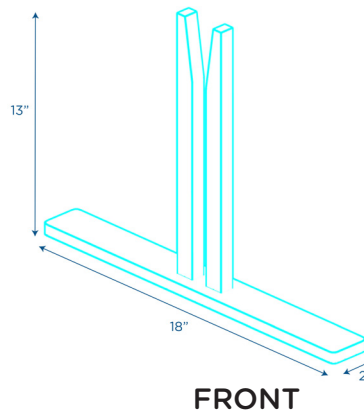
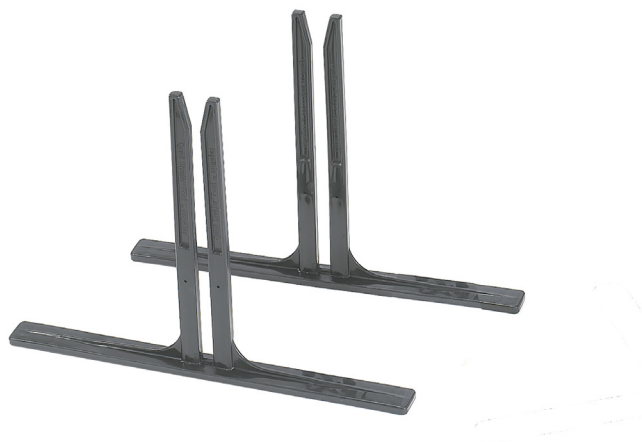

OVERVIEW:

Support feet easily attach to the Quiet Divider® panels to make them stable, free-standing classroom partitions. Quiet Divider® panels are sold separately. Each panel required 2 feet to be free-standing. Set includes 2 feet.

MATERIALS:

Feet are nylon coated black.

Digital Swatches:



Model #	Description	L"	W"	H"	WT lbs.	Cube	FC	Truck Only
AB6811	Quiet Divider® with Sound Sponge® Set of 2 Support Feet (each)	18	2	13	2			N
	Shipping Dimensions	17	17	5.5	5	0.92	250	

ADDITIONAL INFORMATION:

AGE RATING: Adult Use Only

STANDARDS AND TEST COMPLIANCE: N/A

GREENGUARD GOLD CERTIFIED: NO

WARRANTY: 1 Year

KEYWORDS: Partition room dividers; Room partition; Room partitions and dividers; Room divider screens; Screen room divider; Privacy screen room divider; 3 panel room divider; Panel room divider; 4 panel room divider; 6 panel room divider; classroom; nursery; preschool; daycare; homeschool